

# The impact of Thermal bypass

There is mounting evidence to suggest that many buildings designed to achieve thermal performance standards, including the Building Regulations, are often consuming over 40% more energy than their predicted values. In some cases the increase in energy consumption can be up to 70% greater. Mark Siddall, of AECB member company Devereux Architects, comments upon the effects of natural and forced convection upon building performance.

In developing the design for a residential development that incorporates 25 PassivHaus standard homes at the Racecourse Estate, Sunderland, (see last issue) concerns relating to air movement within and through walls, otherwise known as 'thermal bypass', have had a significant influence upon the project. Here Mark Siddall reviews existing literature relating to the subject.

This study serves to develop an understanding of the extent to which thermal bypass mechanisms can impair thermal performance, enable the adoption of appropriate performance targets and, where possible, inform the reader of some of the technical strategies and solutions that are available.

## What is thermal bypass?

Harrje, [1986] describes thermal bypass as heat transfer that bypasses the conductive or conductive-radiative heat transfer between two regions. Defined in this manner, convective loops, which can include both air infiltration and wind washing, constitute a form of thermal bypass. In this context it should be recognised that the term thermal bypass is being applied to largely unfamiliar, and often unregulated, heat transfer. Furthermore it is an acknowledgement that air movement can lead to a significant increase in the heat loss when compared to predicted values. This means that even when the designer thinks that a design has addressed the performance requirement, it is very likely that it has not.

## Thermal bypass and types of air movement

Air movement can occur as a result of natural convection, forced convection (external air flow such as the wind and ventilation) or, as is most common, as a combination of the two. Harrje [1985] identified two forms of convective loop bypass that occur predominantly through natural convection. 'Closed loop' convection may be observed where the air mass remains largely unchanged, but temperature differences exist at the boundaries causing re-circulatory air flow (whereby the air moves in a loop). This phenomenon may not always contribute to the net

exchange of indoor air with the outside, ie. it does not constitute air infiltration; refer to Figure 1 (g,h,i,j).

'Open loop' convection allows an air mass to be replaced by other air and therefore includes air gaps that permit air flow, and thus heat transfer, between two regions; refer to Figure 1 (a,b,c,d,e,f,k,l,m). When air movement is sufficient, due to the wind or stack effect, an open loop can result in the complete elimination of the effectiveness of thermal insulation. Fabric weaknesses such as poor airtightness and windtightness, permit the penetration of external airflow and assist open loop bypass mechanisms.

As not all mechanisms constitute air infiltration they may not be detected through air pressure tests conducted in accordance with BS EN 13829. A consequence of this observation is that infrared thermographic analysis or tracer gas testing may be required to detect some forms of thermal bypass.

## The impact of natural convection upon thermal performance

Natural convection is triggered by differences in air density that arise due to temperature differences. The warmer air at the bottom rises, and consequently the colder, denser air descends due to gravity. The following section reviews the impact that closed loop natural convection can have upon a range of building elements and some common construction methods.

Attics: CFD simulation for insulation at a depth of 0.5m suggests that, in attics, convection within the insulation will not occur until temperatures fall below  $-40^{\circ}\text{C}$  when the density is  $30\text{kg}/\text{m}^3$  for rock wool and  $15$  to  $18\text{kg}/\text{m}^3$  for glass wool [Ciucasu 2005]; refer to Figure 1 (g).

Masonry cavity walls: Lecompte [1990] took over 100 measurements using a calibrated hot box in order to study the influence of gaps and cracks upon heat transfer. The closed loop system studied was a masonry cavity wall with a theoretical U-value of  $0.34\text{W}/\text{m}^2\text{K}$ . The study included wall constructions using mineral fibre and polystyrene insulation. The test wall consisted of 9cm cellular concrete plastered on both sides, and an outer leaf of 12mm ply wood. The height of the wall was 2m. In one of the permutations studied there was a 10mm gap on the warm side of the insulation and a 40mm gap on the cold side of the insulation (the 10mm gap was to simulate mortar snots). Lecompte reports a degradation in the U-value of 193% when there is 10mm wide crack between insulation batts and even a reduction in performance of 158% for a 3mm crack!

Not surprisingly it was concluded that gaps and cracks should be avoided; the influence of workmanship can not be overstated; refer to Figure 1 (i). Building upon the work of Lecompte and others, a synthesis paper considering the hygrothermal behavior of cavity walls has been published. For masonry cavity walls with a theoretical U-value of  $0.2\text{W}/\text{m}^2\text{K}$ , poorly installed mineral fibre insulation was found to be less sensitive to looping than poorly installed foam board. Furthermore it is suggested

# the impact of thermal bypass

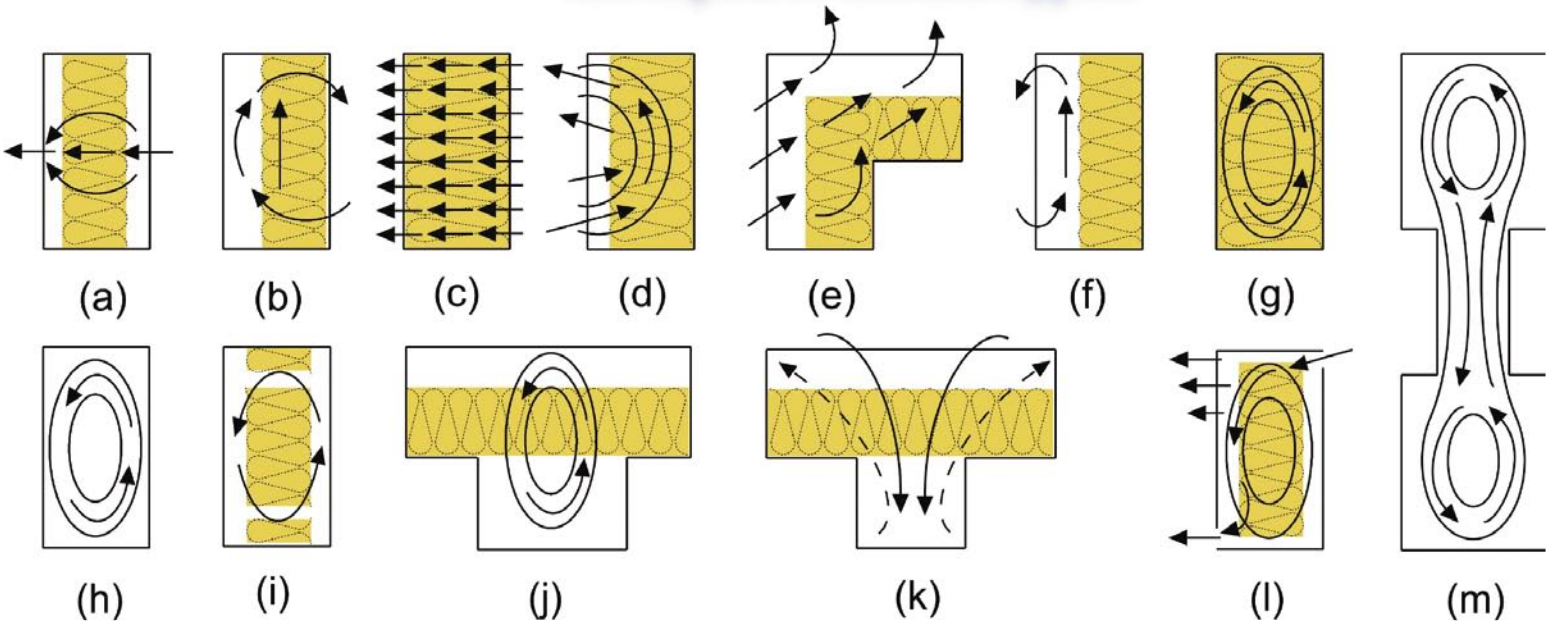
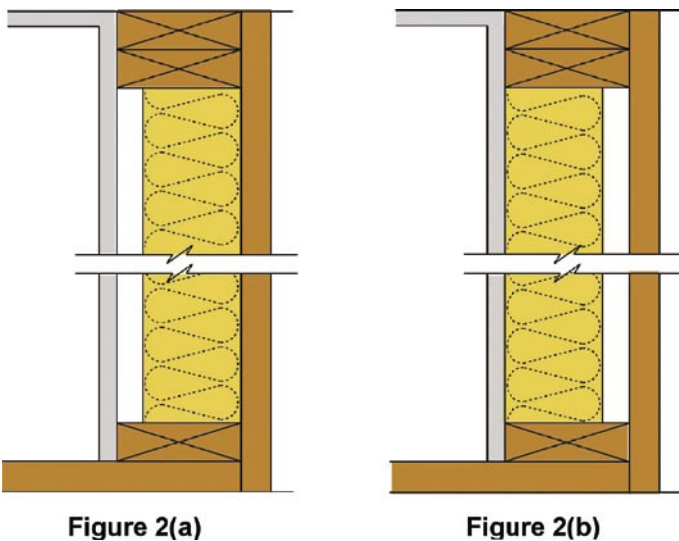

**Figure 1.** Common air flow patterns within insulated and uninsulated cavities: (a) air leakage through gaps (b) infiltration of internal air by natural convection (c) diffuse air leakage (d) infiltration of external air by natural or forced (wind) convection (e) wind washing at a corner/edge (f) ventilation or venting (g) air rotation by natural convection within insulation (h) air rotation by natural convection in an uninsulated cavity (i) air rotation by natural convection around insulation (j) air rotation by natural convection through insulation (k) infiltration of external air by natural or forced (wind) convection through insulation (l) mixed pattern (m) air rotation by natural convection between two regions.

that, compared to a partial fill cavity, a well constructed, drained, unventilated, full-fill cavity wall, with no gaps and cracks, offers the greatest opportunity for successful hygrothermal performance [Hens 2007].

Timber frame walls: when studying timber frame construction and measuring performance across a wall with a temperature gradient of 25°C (20°C int, -5°C ext) Uvsløkk [1996] found that for 150mm mineral wool (31.0kg/m<sup>3</sup>) and 150mm glass wool (21.0kg/m<sup>3</sup>), depending upon installation procedure and the ensuing air gap, the thermal performance could be impacted upon. Two installation procedures were studied.

- Installing from the inside towards the wind barrier (leaving small gaps on the warm side between the insulation and the air barrier) Figure 2(a).
- Installing from the outside towards the air barrier (leaving small gaps on the outside between the insulation and the wind barrier). Figure 2(b).



Air gaps on the warm side (Figure 2a), resulted in a 300% increase in heat loss across a range of wind pressures. These results were considered to be of

particular importance when a less than perfect wind barrier was installed. The issue of gaps behind the insulation and the impact upon performance in timber frame construction has also been noted by Harrje [1985] and Dutt [1985], see Figure 3 (a, b). It is therefore interesting to observe that both timber frame and masonry construction have been found to perform poorly when there are gaps on the warm side of the insulation and cracks between insulation boards.

Hollow walls: recirculatory heat transfer can occur in hollow walls that are formed using multi-cell masonry and

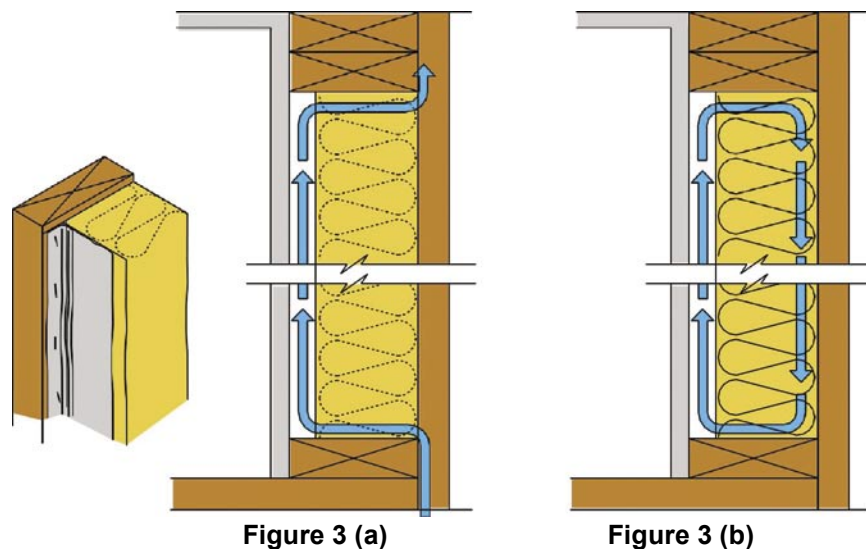

cavity construction; refer to Figure 1(h). Typically these technologies are used in external walls, party walls and basements [Harrje 1985; Wingfield, 2007]. As this form of convective bypass is little appreciated, and its impact upon thermal performance is significant, it is worthwhile exploring this bypass mechanism in more detail.

### Natural convection - a study of thermal bypass at the separating party wall

It was in 2007 that Leeds Metropolitan University measured building performance in housing at Stamford Brook. Here it was found that the whole house heat loss coefficients exceeded the predicted values by between 75% and 103% [Wingfield, 2007]. Warm attics were found to be one of the first signs of thermal bypass. Theoretical analysis suggests that thermal stack driven bypass (i.e. natural convection) in the party wall cavity gives rise to a significant source of heat loss with a magnitude equivalent to an effective, single sided party wall, U-value in the order of  $0.6\text{W}/(\text{m}^2\text{K})$ . To degrade the performance so significantly analysis also suggested that the thermal bypass would need to be fed by cold external air entering from the bottom and sides of the cavity. The postulated bypass mechanism at Stamford Brook is shown in Figure 4. It was considered that forced convection played a lesser part in the role of thermal bypass.

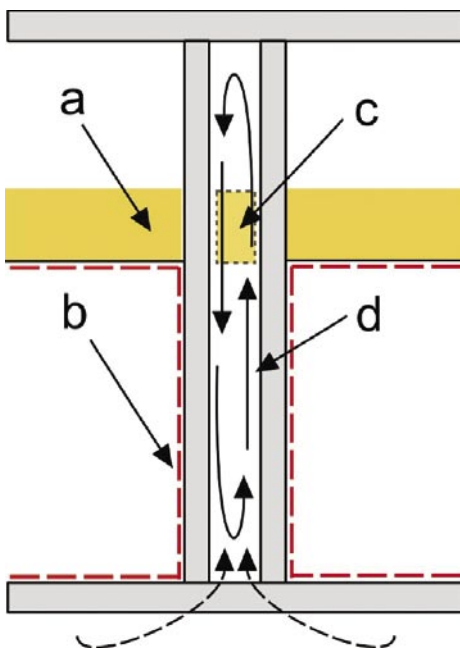

**Figure 4.** a) insulation, b) airtight barrier, c) cavity sock, d) cavity.

To investigate a cost effective means of addressing this thermal bypass a mineral wool-filled cavity sock was positioned horizontally in the party wall cavity at the level of the ceiling insulation. This was partially successful at mitigating losses and reduced the single sided effective U-value to between  $0.1$  and  $0.2\text{W}/(\text{m}^2\text{K})$ . This is a considerable improvement upon the base case, however, in the context of low energy buildings the heat loss remains significant.

It should be noted that, compared to UK standards, the PassivHaus standard uses a different measurement convention, furthermore, when adopting the standard,

in order to maintain the zero thermal bridging concept, it requires that a thermal bridge does not exceed  $0.01\text{W}/(\text{mK})$ . On this basis, to appreciate the impact of the cavity sock upon performance in a building designed to the PassivHaus standard, one needs to convert the effective U-value into an effective linear thermal bridge (psi-value). Thus when the party wall heat losses are measured externally along a notional  $5 \times 8\text{m}$  party wall, the single sided effective psi-value for the unaddressed condition is closer to  $\sim 1.33\text{W}/(\text{mK})$  and with the cavity sock ranges from  $\sim 0.22$  to  $\sim 0.44\text{W}/(\text{mK})$ . The cavity sock clearly fails to achieve the zero thermal bridging requirement.

Consequently it was determined that at the Racecourse Estate an alternative to the cavity sock needed to be considered. Logically the first step was to identify case studies of terraced housing that have been designed to the PassivHaus standard; hopefully such a development would be well documented and address closed and open loop thermal bypass at the party wall. This would offer greater certainty about which detailing solution should be considered to be most appropriate in the UK context.

### Addressing thermal bypass at the party wall: part 2

One of the most carefully catalogued PassivHaus schemes is to be found at Kronsberg, Hannover [Feist, 2005]. A review of the construction details and the technical studies suggest that it succeeds at preventing thermal bypass at the party wall. The strategy used differs considerably to conventions in England and Wales. By utilising a membrane to close the party wall cavity, insulation above to prevent conductive heat loss, and a wind barrier externally, closed loop thermal bypass appears to have been mitigated. A further benefit of this particular detail is that the detailing principle serves to tackle the geometric thermal bridge that would otherwise arise as a result of a topographical level change. From this analysis the party wall detail developed for the Racecourse Estate utilises a membrane to both close the cavity, thus preventing bypass, and achieve airtightness. Refer to Figures 5 and 6.

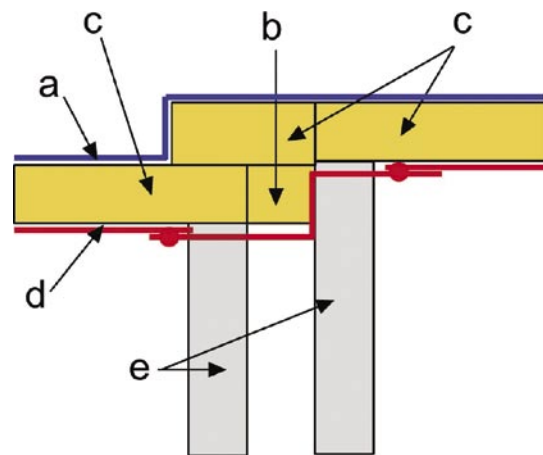
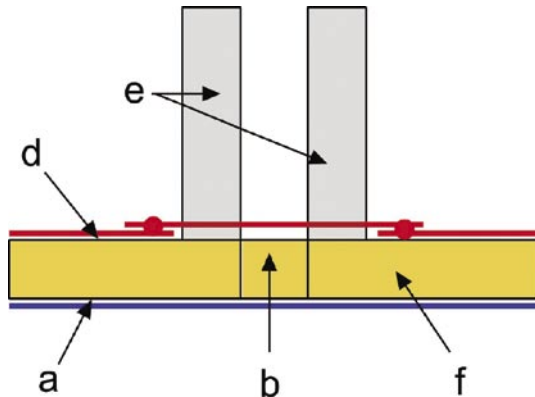

**Figure 5.** a) weather barrier, b) site insulation, c) insulated roof cassette, d) air barrier, e) party wall.

At Racecourse the proposed PassivHaus project will

# the impact of thermal bypass

utilise timber frame construction, as opposed to masonry (which was used at Stamford Book). However, it can be observed that typical UK construction details for terraced housing contain many of the same deficiencies as those found at Stamford Book. On this basis the strategy of using the membrane to close the cavity was considered to still be appropriate.



**Figure 6.** a) weather barrier, b) site insulation, c) insulated roof cassette, d) air barrier, e) party wall, f) external wall cassette.

In order to help achieve an appropriate detailing solution that tackled airtight construction, thermal bypass, acoustics and fire spread, it was deemed necessary to move away from the traditional trussed rafter and adopt a design that utilises a compact roof. This is a more continental detail that relies upon warm roof construction. The issues arising from selecting this technology will be discussed later.

## The impact of forced convection upon thermal performance

Forced convection includes the case where cold air moves along the surface of a warmer material and at the surface the material temperature drops, and the case where cold air penetrates the insulation, often due to poor function of the wind protection and airtightness. Airtightness may be defined as 'the property of preventing air from penetrating through the shell' and windtightness as 'preventing air from penetrating into the shell so that the thermal insulation property of the insulation material is not reduced'. Wind washing can affect the thermal performance of low density insulation, short-circuit the performance of insulating sheathing, and cool down an air barrier system located towards the outside of the wall assembly (potentially below the dew point temperature). Refer to Figure 1 (d,e,f&k).

## The impact of airtightness upon thermal performance

Airtight design has the effect of decoupling the internal environment from the external one. By preventing airflow through the building envelope, perpendicular air movement through a buildings thermal insulation can be largely avoided. Bankvall [1978] reports that for a wall with a 20pa pressure difference between inside and out (equivalent to a velocity of 2.5m/s) the air flow through 300mm of insulation would result in a 35% reduction in thermal performance. For this reason airtight construction is a prerequisite and all joints, cracks and services

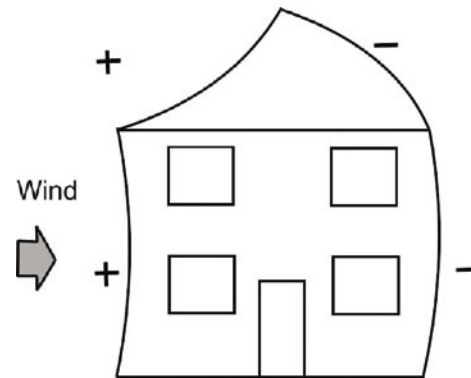

**Figure 7.** a 20pa pressure difference between inside and out (equivalent to a velocity of 2.5m/s) the air flow through 300mm of insulation would result in a 35% reduction in thermal performance. Bankvall [1978].

penetrations through the air barrier should be sealed accordingly.

Due to the exacting airtightness requirement of 0.6 air changes per hour at 50 Pascals (ach/hr@50pa), residential construction achieving the PassivHaus standard can be considered to address a number of potential bypass mechanisms, Figure 1 (a,b & c). This is not to say that the PassivHaus standard is beyond reproach. As the standard is based upon an air change rate, rather than air permeability ( $\text{m}^3/(\text{m}^2\text{h})@50\text{pa}$ ) in larger buildings the air permeability can exceed the performance standards recommended in Table 1 (page 21), and as a consequence the losses from thermal bypass could be a matter for concern. Another concern is that whilst the PassivHaus standard considers airtightness, any performance risks arising from windtightness and close loop bypass, are not directly addressed, ie. it remains within the remit of the diligent designer/constructor.

## The impact of windtightness upon thermal performance

Studies have shown that the wind can have a significant impact upon the thermal performance of timber frame construction. Research into the effects of forced convection, where the air flow is parallel to fibrous insulation, has been undertaken for a range of building elements. The following section reviews some of these findings.

**External walls:** a windtight wall subject to an air velocity of 2.5m/s parallel to the insulation (density 16.3kg/ $\text{m}^3$ ) with 'no' defects can witness a 10% degradation in performance. If the same wall is subject to defects, such as gaps and cracks, then a significant decrease in performance of 40% can occur as result of air movement through the insulation Bankvall [1978]. Uvsløkk [1996] have conducted measurements that demonstrate that, across a range of air pressures, air penetration through a defective wind barrier has significant thermal effects upon insulated timber frame construction, leading to heat losses that are three to ten times higher than those considered in ideal constructions. Timusk [1991] developed detailed accounts of severe wind cooling at the corners of a

number of timber frame homes in Canada; here as a result of rapid pressure changes, in combination with thermal bridging and indoor humidity, low surface temperatures resulted in condensation, mould and fungus growth.

**Attics:** hotbox tests on attic insulation [Taylor 1983] found that an air velocity of 1.0m/s parallel to the insulation resulted in a 40% reduction in thermal resistance (insulation density 10 to 12kg/m<sup>3</sup>). When ill-fitting insulation was subject to 5% gaps lengthwise and widthwise, results indicated a 60% reduction in the thermal resistance.

### The impact of air velocities within cavity upon thermal performance

With regard to air movement, the above discussion is only meaningful if the velocity of the air within a cavity can also be appreciated.

**Ventilated facades:** cavity velocities within a ventilated masonry facade have been reported not to exceed 0.2m/s, when the maximum external air speed was in the region of 7.5m/s [Silerbsein 1991]. Bankvall [1978] observes that even velocities of ~0.1m/s can have a 'noticeable' (but unquantified) impact upon thermal resistance.

**Ventilated pitched roofs:** Anderson [1981] studied air speeds within a loft space and concluded that, with external wind speeds ranging up to 10m/s, the corresponding air speed within the loft was 0 – 0.3m/s (98% of measurements were within the range 0 – 0.1m/s). In conclusion, in ventilated pitched roof construction, the greatest risk to performance lies at the eaves where external air is introduced through ventilation slots. For this reason suitable wind protection should be provided. Refer to Figure 1 (e) and Figure 8.

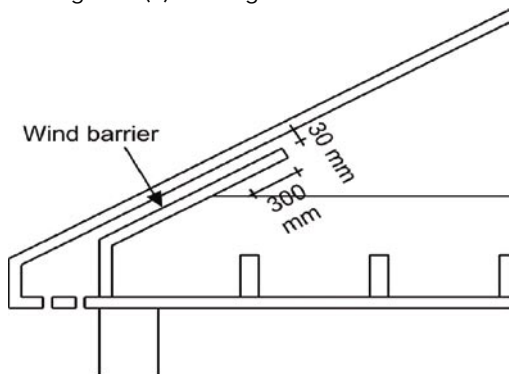

Figure 8. Wind protection measures.

**Compact roof (cathedral roof):** cavity velocities of up to 1.5m/s were reported within an insulated cathedral roof pitched at 22 degrees where the external windspeed was no higher than 7m/s [Silerbsein 1991]. Reference to Bankvall suggests that this cavity velocity is significant and poses a risk to performance. As a consequence it warrants greater consideration; especially as this roof type is to be used at the Racecourse Estate.

### Wind washing - detailed case study: ventilated and unventilated compact (cathedral) roofs

It can be observed that thermal performance is not simply a consequence of increasing the thickness of insulation but also that of the protection and encapsulation of the insulation through good design and workmanship. Two case studies relating to the performance of compact roof and ventilated cathedral have been identified.

The test roofs that were constructed had a good theoretical U-value of 0.2W/(m<sup>2</sup>K). Monitoring included the use of tracer gasses and thermocouples. During the course of the study the moisture performance of the roofs was also monitored and all roofs performed adequately.

The final design U-value was 0.18W/(m<sup>2</sup>K). For an external wind speed of 4m/s the U-value of the unventilated compact roof increased by 0.02W/(m<sup>2</sup>K), whilst the U-value of the ventilated compact roof it rose by 0.07W/(m<sup>2</sup>K). Thus the unventilated roof was degraded by 11% compared to the theoretical U-value whereas the ventilated roof was degraded by 39%. It was concluded that to minimise wind washing, all joints in the membrane should be sealed (at least taped, but ideally clamped under battens) and that the underlay should have a low permeance in accordance with Table 1. Particular attention should be given to joints at the eaves, verge and ridge.

Deseyve [2005]: This investigation into new homes in Austria serves to highlight the fact that air movement though insulation can have a substantial impact upon thermal comfort, as well as energy performance. U-values as high as 2.5W/(m<sup>2</sup>K) were recorded under external wind conditions of 7 to 9m/s. It is reported that the U-value fluctuated by as much 660%. The extreme degradation through wind washing was due to bulk air movement occurring as a result of cold external air entering at eaves level and being drawn up through the insulation into a small attic space, at high level, that is ventilated to the outside.

### Performance targets: risk elements and control

Janssens [2007] notes that Di Lenardo has considered both moisture accumulation and energy conservation when establishing the upper limit for the air permeance of the air barrier, including joints and penetrations. The upper limit was defined by limiting the air leakage to 15% of the conductive heat transfer through an insulated wall in the Canadian climate. Janssens also draws upon Uvsløkk and Ojanen noting that they derived air permeability requirements for wind barriers in timber frame construction; these parameters seek to limit heat loss by wind washing to less than 5% of the conductive heat flow

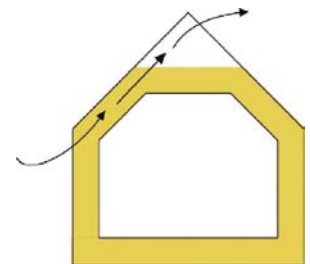
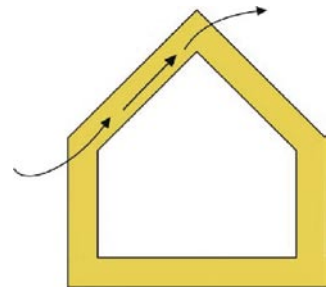

# the impact of thermal bypass

**Table 1.** Air leakage criteria taken from Janssens [2007] after Uvsløkk and Di Lenardo.

Application	Air leakage (m <sup>3</sup> /(m <sup>2</sup> h) (75pa)	Air permeance (m <sup>3</sup> /(m <sup>2</sup> s/pa)	Air permeability (m <sup>3</sup> /(m <sup>2</sup> h) (50pa)
Air barrier material	< 0.07	< 0.3 x 10 <sup>-6</sup> (a)	< 0.054(b)
Air barrier system (inc. joints)	< 0.72	< 2.7 x 10 <sup>-6</sup> (a)	< 0.486(b)
Wind barrier (inc. joints)	< 3.75 (a)	< 14.0 x 10 <sup>-6</sup>	< 2.52(b)

(a) Janssens extrapolation assuming a linear flow pressure relation

(b) Siddall extrapolation assuming a linear flow pressure relation

Note that the Uvsløkk's 5% performance standard was derived from a wall utilising 150mm insulation and that dependent upon the insulation type the hot box U-value was roughly 0.28 W/m<sup>2</sup>K.

in a Scandinavian climate. Table 1 lists the suggested air and wind barrier performance as noted by Janssens.

## Designing to avoid thermal bypass

The principle recommendations are to eliminate air gaps within and either side of the insulation layer, to preserve airtight construction, and to protect the insulation layer against wind induced air movement. A number of simple guidance notes for designing and constructing air and wind tight barriers emerge from this basis premise.

1. Mark up the plans, sections and details so that they clearly delineate the air barrier, (say using a red line for airtightness and a blue line for windtightness).
2. Ensure that the respective barrier remains unbroken. Pay particular attention to continuity at structural openings and services penetrations. If you identify any gaps find a simple solution that allows the barrier to be continuous.
3. Keep it simple, keep it safe: avoid unnecessary kinks and bends (avoid complicated solutions that require skills in origami).
4. Minimise the number of joints: when using/specifying membranes use wide rolls or continuous wet finishes
5. Seal all joints: use caulking or tape and mechanically clamp the joint between two solid plates (say between a stud and plasterboard). To assist sealing fix membranes vertically from eaves to sole plate so that the side lap coincides with a stud (similarly ridge to eaves for the roof). This ensures that the joint can be filled with mastic and/or taped with a batten nailed over to give a long-term physical connection.
6. Consider building movement and settlement. For wet barriers consider reinforcing the corners using membranes covered with expanded metal, and provide membranes at window junctions. Membranes should overlap by 150mm and should not be pulled tight at the corners (leave a half round loop 5-10mm diameter

- at movement joints, windows, eaves, ridge etc).
7. Do it once, do it right: determine the principle air barrier and ensure that this is tested and, where necessary, repaired. Do not rely upon the secondary sealing of non-air barrier systems to achieve airtightness (this is costly, time consuming and very likely to result in poor longevity of the air barrier).
8. Encapsulate the insulation between the wind and air barrier.
9. Voids should be designed out: especially those that remain on the warm side of the insulation (you may need to consider the insulation installation methodology: e.g. for timber frame installation from the outside towards the air barrier). Insulation must completely fill the element but must not be compressed too much such that deformations occur. Insulation should be about 5 to 10mm thicker than required so that the closing board will lightly compress the insulation along the entire surface area.
10. Avoid the formation of interlinking cavities by designing the building elements as discrete components, ie. close cavities at wall to wall junctions (including corners), between walls and roofs and walls and floors.

## Air and wind barrier concepts and strategies

A range of wind and air barrier options exist. Table 2 has been developed with reference to Elmroth [1983] Timusk [1991] and Proskiw [1997] and modified from Carlsson [1980].

### Pressure equalization and compartmentalization for wind barriers

Ventilated cavities are often utilised to prevent rainwater from entering the building. After studying hygrothermal performance Hens [2007] has cast doubt on the need for ventilation within masonry walls. However, timber framed building will still require a ventilated cavity.

**Table 2.** Air and wind barrier concepts and strategies, (continues on next page).

Method	Detail	Advantages	Disadvantages
Internal airtight cladding e.g. plaster, parge or, plasterboard		<ul style="list-style-type: none"> <li>• Uses common sheet properties</li> <li>• Can be checked relatively easily and rectified where necessary</li> </ul>	<ul style="list-style-type: none"> <li>• The sheet lies unprotected</li> <li>• Risk of puncturing during construction and building life</li> <li>• The joints must be sealed carefully even against floors and roofs e.g. sensitive to movement and subsequent crack formation</li> </ul>

**Table 2 (continues).** Air and wind barrier concepts and strategies.

Method	Detail	Advantages	Disadvantages
Internal sealing layer e.g. foil		<ul style="list-style-type: none"> <li>• Vapour barrier can naturally be used for air sealing as well</li> <li>• Large size foil sheets can be used, with few joints as a result</li> </ul>	<ul style="list-style-type: none"> <li>• Certain difficult construction problems</li> <li>• Accuracy required at joints</li> <li>• Risk of puncturing during construction and building life</li> <li>• Services installation penetrations cause problems</li> </ul>
Drawn under sealing layer e.g. paper or foil		<ul style="list-style-type: none"> <li>• The air sealing layer is protected against damage</li> <li>• Electrical installations, DIY projects, and future rewiring etc (during the operational life) is possible without the sealing strip being damaged</li> <li>• Good prospects of achieving high level of airtightness</li> <li>• Reduced risk of puncturing during construction and building life</li> </ul>	<ul style="list-style-type: none"> <li>• Moisture damage risks not known</li> <li>• The effects of supplementary insulation and carpentry and furnishing, e.g. on moisture conditions in the sealing strip, in particular, are unknown</li> <li>• Requires double wooden frame</li> </ul>
External air sealing and wind protection		<ul style="list-style-type: none"> <li>• The wind protection systems air sealing properties can be used and it can form a part of a pressurized rainscreen</li> <li>• Allows early installation, inspection, testing and remediation without disruption to programme and before substantial completion</li> <li>• Allows for the conventional scheduling of sub-trades and ease of site access and has fewer complicated junctions</li> <li>• Barrier not penetrated by floors, partitions, or electrical services therefore avoiding the need for cable seals/polypan or strapping to accommodate services and can be repaired externally before being covered</li> <li>• Electrical installations, DIY projects, and future rewiring etc (during the operational life) is possible without the sealing strip being damaged</li> <li>• Allows single expenditure for multiple benefits</li> </ul>	<ul style="list-style-type: none"> <li>• Significant risk that airtightness is so good that moisture can condense inside the construction (ensure suitably vapour permeable wind barrier)</li> <li>• The layer is affected by the external climate consequently materials and joints are exposed to more extreme moisture and temperature conditions in order to ensure long term integrity suitable methods for sealing the envelope should be considered</li> <li>• Stringent requirements on internal vapour barrier</li> <li>• Provided that a reliable and effective vapour barrier system is employed on the warm side of the building fabric moisture diffusion can be attenuated</li> </ul>
Combination of internal and external air sealing		<ul style="list-style-type: none"> <li>• Double safety for air sealing</li> </ul>	<ul style="list-style-type: none"> <li>• Use of double sealing layers is uneconomic</li> <li>• An airtight wind protection can cause moisture damage if inappropriately specified</li> </ul>
Homogenous constructions eg. cellular concrete		<ul style="list-style-type: none"> <li>• Simple design</li> <li>• Electrical cables can be included without jeopardising airtightness</li> </ul>	<ul style="list-style-type: none"> <li>• Limited choice of materials</li> <li>• Connection details to other materials have to be solved separately</li> <li>• All building sections should be able to be carried out applying the same system which limits the method and choice of material.</li> </ul>

**WARNING FOR THIS DETAIL**  
 A combined external wind/air barrier could permit windwashing. This would occur as a result of the wind/air barrier acting like a diaphragm whereby warm internal air is drawn into the depth of the wall element assisting heat loss and thus increasing the U-value. This action could also draw moisture into the structure.  
 There is also the risk that the convective currents that are present within a building (induced by opening external doors, MVHR etc.) could assist the vapour transport through any unsealed joints in the vapour barrier. This action could also draw moisture into the structure.

# the impact of thermal bypass

The details that tend to be most susceptible to wind washing are vertical corners and the tops of walls (eaves, verge and ridge), horizontal and pitched assemblies (such as raised insulated floors that separate an unheated garage from a living space above and cantilevered or suspended living spaces and compact/cathedral roofs). The key to controlling this phenomenon is to increase the resistance to external airflow circulation; as noted above this may be achieved by air and wind tight construction and the compartmentalisation of the cavity behind a rainscreen (this may be achieved with vertical furring strip). Refer to Figure 1 (d,e).

## Regulatory matters: current status

A quick survey of European standards suggests that limited attention has been given to the mechanisms of convective thermal bypass and its subsequent control. Airtightness appears to be the topic that is highest on the agenda. In the context of thermal bypass similar regulatory failures exist in Austria [Deseyve, 2005], England and Wales [Wingfield 2007] and even advanced voluntary standards such as the PassivHaus standard do not explicitly consider the issue of thermal bypass at party walls [Warm, 2008] or windtightness.

## Conclusion

For buildings to perform as required the ability to recognise and avoid thermal bypass mechanisms is critical. Industry wide training, provided at a national, European and international level, is necessary. This training should be supported by revisions to building regulations in such a way that it is a requirement that all building elements should be adequately airtight and windtight in all directions so that all potential closed loops are protected from temperature gradients at boundaries (which can induce convection) and that any open loops are designed out.

Mark Siddall [m.siddall@devereux.co.uk](mailto:m.siddall@devereux.co.uk)

Mark, sustainability champion at Devereux Architects, has conducted detailed research into low and net-zero carbon technologies. In addition to being one of the practice's lead designers, Mark also provides consultancy, project enabling and education for clients, design teams and constructors. Currently he working on what is understood to be the UK's first major PassivHaus scheme (25 homes) and is providing consultation for the Riverside One Net-Zero Carbon development in Middlesbrough (a significant scheme for Bio-Regional Quintain). Mark has presented two papers at the International PassivHaus Conference; one on advanced glazing and another on thermal bypass.

**This story was first published in Green Building Magazine, Summer 2009 (Volume 19 No 1) and is copyright of and reproduced with permission from Green Building Press.**

## Refs

- [AECB 2007] AECB/CarbonLite, *Energy Performance Standards (2007) downloaded 21.02.08 from [www.carbonlite.org.uk/carbonlite/downloads.php](http://www.carbonlite.org.uk/carbonlite/downloads.php)*
- [Anderson1981] Anderson BR, Ward TI, *Measurements of heat loss through an insulated roof, Building Services and Research Technology, Vol 2, No.2, 65-72 (1981)*
- [BS EN 13829] BS EN 13829: *Thermal performance of buildings, Determination of air permeability of buildings: Fan pressurization method, British Standards Institute (2000)*
- [Bankvall 1978] Bankvall CG, *Forced Convection: Practical Thermal Conductivity in an insulated structure under the influence of workmanship and wind, ASTM STP 660, 409-425 (1978)*
- [Carlsson 1980] Carlsson B, Elmroth A, Engvall P, *Airtightness and Thermal Insulation: Building Design Solutions, Swedish Council for Building Research (1980)*
- [Dutt, 1985] Dutt G, Nilsson N, *Superinsulated Home Book; John Wiley (1985)*
- [Deseyve, 2005] Deseyve C, Bednar T, *Increased Thermal Losses caused by Ventilation through Compact Pitched Roof Constructions – In Situ Measurements, Seventh Nordic Building Physics Symposium (2005)*
- [Elmroth, 1983] Elmroth, *Air infiltration control in housing – A guide to international practice, AVIC/Swedish Council for Building Research, Stockholm, Sweden (1983)*
- [Feist, 2005] Feist W, Peper S, Kah O, von Oesen M, *PEP Project Information No. 1, Climate Neutral Passive House Estate in Hannover- Kronsberg: Construction and Measurement Results (2005)*
- [Harrje, 1985] Harrje DT, Dutt GS, Gadsby KJ, *Convective Loop Heat Losses in Buildings. ASHRAE Transactions 91(2): 751-760 (1985)*
- [Harrje, 1986] Harrje DT, Dutt GS, Bohac DL, Gadsby KJ, *Documenting Air Movements And Infiltration In Multicell Buildings Using Various Tracer Techniques. ASHRAE Transactions 91(2): 2012-27 (1986)*
- [Hens et al 2007] Hens H, Janssens W, Depraetere J, Carmeliet J, Lecompte J, *Brick Cavity Walls: A Performance Analysis Based upon Measurements and Simulations, Journal of Building Physics vol 31, 95 - 123 (2007)*
- [Janssens 2007] Janssens A, Hens H, *Effects of wind on the transmission heat loss in duo-pitched insulated roofs: A field study, Energy and Buildings 39, 1047-1054 (2007)*
- [Lecompte 1990] Lecompte J, *The Influence of Natural Convection on the thermal quality of insulated cavity construction, Building Research and Practice 6, 349 - 354 (1990)*
- [Proskiw, 1997] Variations in Airtightness of Houses Constructed with Polythene and ADA Air Barrier Systems Over a Three-Year Period, Proskiw G, Eng P, *Journal of Building Physics, vol 20, 278-296 (1997)*
- [Silberstein, 1991] Silberstein A, Arquis E, McCaa DJ, *Forced convection effects in fibrous insulation, ASTM STP 1116, 292 - 309 (1991)*
- [Taylor, 1983] Taylor BE, Phillips AJ, *Thermal transmittance and conductance of roof constructions incorporating fibrous insulation, ASTM STP 789, 479 - 501, (1983)*
- [Timusk 1991] Timusk J, Seskus A.L, Ary N, *The control of wind cooling of wood frame building enclosures, Journal of Thermal Insulation 15 8-19 (1991)*
- [Uvsløkk 1996] Uvsløkk S, *The importance of wind barriers for insulated timber frame constructions, Journal of Thermal Insulation and Building Envelopes 20, 40-62. (1996)*
- [Wingfield, 2007] Wingfield J, Bell M, Bell JM, Miles-Shenton D, South T, & Lowe RJ. *Evaluating the Impact of an Enhanced Energy Performance Standard on Load-Bearing Masonry Domestic Construction, Interim Report Number 7, Centre for the Built Environment, Leeds Metropolitan University (2007)*
- [Warm, 2008] Warm P, Clarke C, *Projecting energy use and CO<sub>2</sub> emissions from low energy buildings: A comparison of the PassivHaus Planning Package (PHPP) and SAP, AECB (2008) downloaded 22.11.08.*